

Response time measurement of hygrometers at LNE-CETIAT

Eric Georgin^{1*}

¹LNE-CETIAT, 25 Avenue des arts, 69100 Villeurbanne, France

Abstract. LNE-CETIAT has been involved in European project JRP HIT – EMPIR (www.empir-hit.eu). The objectives of this project were to improve the accuracy of industrial humidity measurements, to provide new traceability capabilities and to develop new calibration techniques at high temperatures up to 180 °C and under transient conditions. Considering the last aspect, LNE-CETIAT has worked on the development of a humidity step generator for studying response time of hygrometers. Indeed, classical calibrations are performed under quasi-static conditions whilst the end users measurement conditions are, most of the time, non-static or dynamic. In order to tackle this situation, LNE-CETIAT has started to develop a dynamic humidity generator which enables response time measurement by applying humidity step to the device under test. In this article the test rig is presented as well as results obtained with chilled mirror hygrometers. A discussion about response time of chilled mirror concludes this work.

1 Introduction

To minimize measurement uncertainties as well as handling and accuracy needs, calibrations are usually performed in well controlled static environments. In the humidity and temperature field, this is achieved via static reference generators which deliver steady state conditions and spatially homogeneous working volumes. Under such conditions, typically a low number of static “comparison points”, within the instruments calibration range, is provided to end user in a calibration certificate. Nevertheless, in the field situation the instruments are usually used in non-steady-state, temporally variable conditions, This raises questions about the sensors ability to catch dynamic events, the sensor response time or the validity of a calibration at discrete measurement points under static conditions for dynamic measurement scenarios.

In the framework of the HIT-project, 14IND11 EMPIR, LNE-CETIAT has continued to develop its dynamic humidity step generator. Indeed, this work, initiated within the METEOMET2-project, ENV58 EMRP, has been upgraded to improve the temperature, pressure and flow ranges that can be covered.

The dynamic humidity generator from LNE-CETIAT includes permeation tubes for humidification, a set of mass flow controllers in thermostatic box, high-speed temperature-

* Corresponding author: eric.georgin@cetiat.fr

stabilized valves, enabling defined humidity steps in flow chamber where devices under calibration can be characterized.

2 Humidity step generator

overview

The following facility has been partially described in reference [1]. In this article some additional information and improvements are presented.

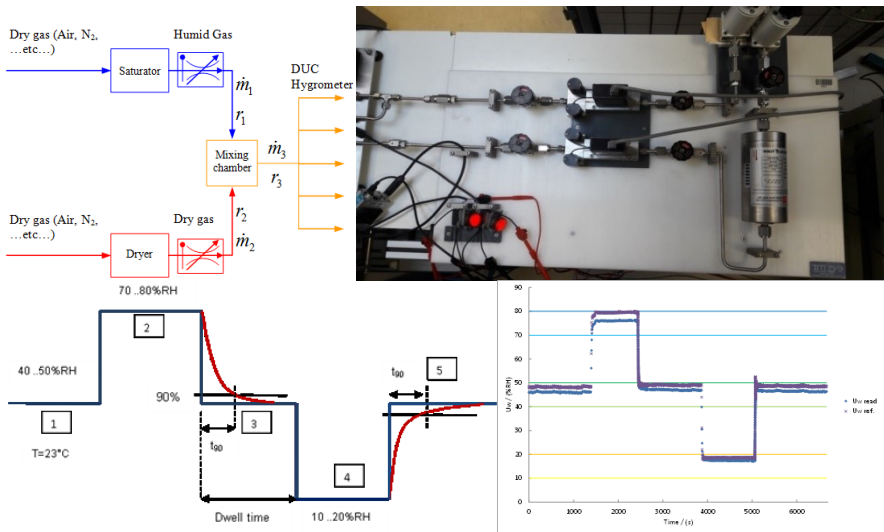

Fig. 1. Humidity step generator developed at LNE-CETIAT [1]

LNE-CETIAT has worked on its humidity step generator since a couple of years now. Namely implementation of french standard NFX15113 dealing with impedance hygrometer qualification. This standard requires namely to realize humidity as presented above. The idea at this time was based on a mixing flow facility composed by a dry line, a wet line and MFC on each line. By changing the MFC flow ratio while keeping constant the total flow we change the humidity delivered to DUT. Steps were controlled by MFC valves.



Fig. 2. Improvements of humidity step generator [1]

During METEOMET project this concept has been improved especially about the way humid gas and dry gas were mixed. A switching device with pneumatic valves has been developed and also thermalization of testing chamber has been added.

Within HIT project, one supplementary MFC has been added and has been set in a thermostated box, up to 50 °C, in order to avoid any unwanted condensation with humid gas.



Fig. 3. Thermalization of MCF

The switching device, has been added in order to achieve faster humidity steps than with the MFCs valves.



Fig. 4. Switching device

Thanks to this device, it is possible to achieve identical flows between 2 steps, with only small pressure fluctuations and the humidity steps are sharper than with the MFCs valves; the switching device is thermalized up to 50 °C which enabled to handle humid air close to 40 °C / 45 °C in dew point temperature.

In order to avoid any unwanted condensation, all the tubes and lines are heated:



Fig. 5. Heated tubes and permeation tubes

Gas supply is ensured by clean dry air on line n°2 and the humidity generation is controlled by 2 permeation tubes set on line n°1 and n°3, see below.

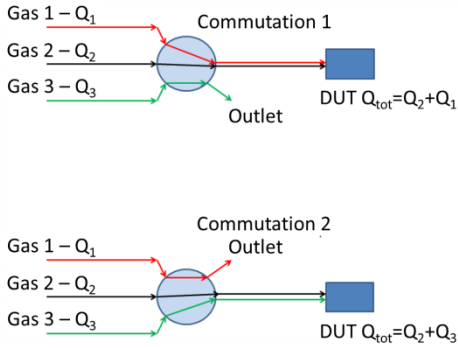

Fig. 6. Schematic diagram of the switching device

Thus the humidity of the humid line n°1 is significantly different from the humidity of the humid line n°2. The final combination is either line 1 + line 2 or line 3 + line 2.

2.3 Preliminary results

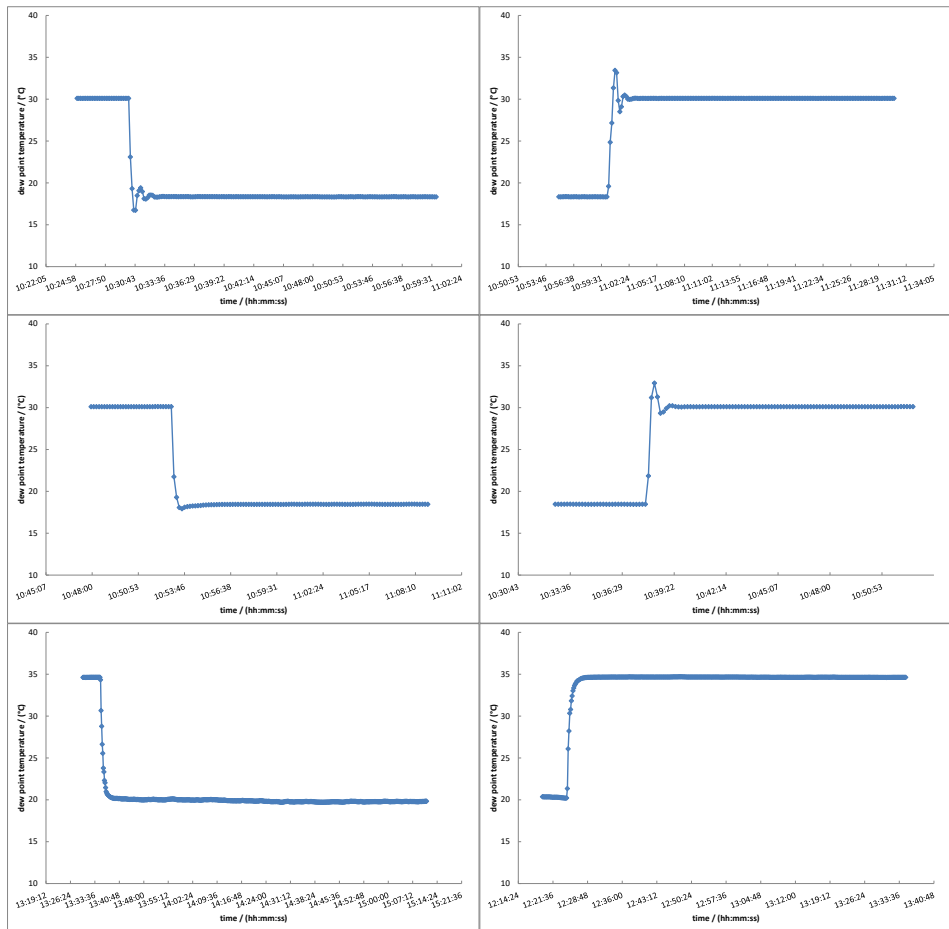

Fig. 7. Response curve, as function of time, for one chilled mirror hygrometer

Preliminary results that have been obtained with one chilled mirror hygrometer are presented above. Left hand plots represent decreasing humidity steps while right hand plots represent increasing humidity steps. From the top to the end, the experimental conditions are relatively high flow and 30 °C in dewpoint temperature (highest step), slow flow and 30 °C in dewpoint temperature (highest step) and slow flow and 35 °C in dewpoint temperature (highest step). We may notice the influence of the flow on the second order shape of the curve.

3 Conclusion

LNE-CETIAT has now developed a tool for studying response time of hygrometers. This work will continue by focusing first on chilled mirror hygrometers. Influence parameters such as dew point level, height of the step, the pressure and the flow will be investigated.

4 Acknowledgements

This work was funded by the Joint Research Project ENV58 METEOMET of the EMRP program, the Joint Research Project 14IND11 HIT of the EMPIR and co-funded through the French metrology LNE-DRST.

The EMRP is jointly funded by the EMRP participating countries within EURAMET and the European Union.

The EMPIR initiative is co-funded by the European Union's Horizon 2020 research and innovation programme and the EMPIR Participating States

References

1. Geogin E. *et al.*, Implementation of qualification benches according to NF X 15-113, proceedings of 17th International Congress of Metrology, Paris – France, (2015)